

OB series

Cleaning covers



Technical data

Accessories

Cleaning covers

The pressure die-cast aluminium alloy cleaning covers offer superior mechanical strength and are manufactured to DIN 24339 standard. They provide easy access to the inside of the oil tank for inspection and cleaning purposes, without necessarily having to dismantle the unit. On request and also for small quantities inspection doors can be supplied with:

- customer logo
- hole cut for visual level indicator
- hole cut for visual and electrical level indicator
- oil sample plug

Compatibility with fluids

- Mineral oils types HH-LL-HM-HR-HV-HC, to ISO 6743/4 standard
- Water based emulsions types HFAE-HFAS, to ISO 6743/4 standard
- Water glycol type HFC, to ISO 6743/4 standard: ask for anodized version

OB275 and OB400 cleaning covers are designed according to DIN 24339.

Materials

- Cleaning covers: Pressure die-cast aluminium alloy
- Seal: NBR 70 Shore A

Weight	with seal	without seal
OB275	2.06 kg	1.76 kg
OB350	2.10 kg	1.80 kg
OB356	2.10 kg	1.80 kg
OB400	3.20 kg	2.90 kg
OB475	3.70 kg	3.40 kg

Operating temperature

From -30 °C to +80 °C



Designation & Ordering code

COMPLETE CLEANING COVER

Size

OB275

OB350

OB356

OB400

OB475

Available customization

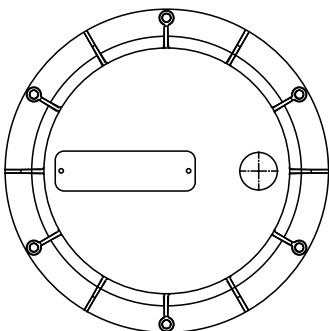

Nameplate with customer logo
Ordering information: **OB475LOGOP05**

The nameplates applied to the new inspection door are identical to those applied to the old door. The difference with the new door is that nameplates are fixed with rivets.

For ordering information codes, minimum order quantities, fixing hole positions and other details not indicated in this publication, contact MP Filtri Technical and Sales Department.

OB275

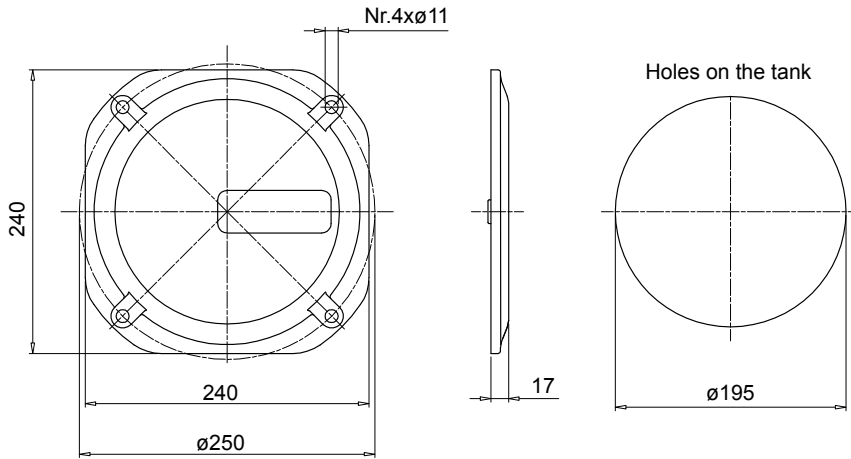

Code	Description	Seal
OB275P01GN	Door with MP Logo	NBR
OB275P02GN	Blank cover	NBR
OB275P01GV	Door with MP Logo	FPM
OB275P02GV	Blank cover	FPM

Code	Description
OB275P01	Door with MP Logo
OB275P02	Blank cover
GU0275NBR	Seal
GU0275VTN	Seal

OB400

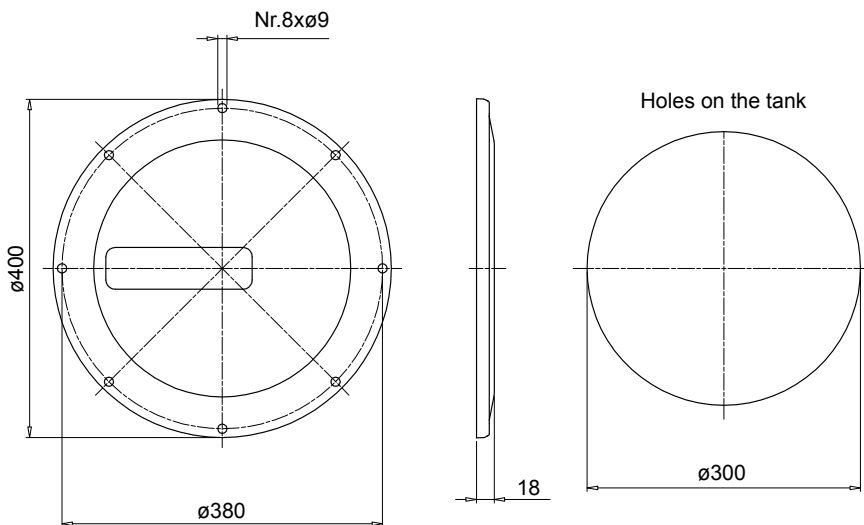

Code	Description	Seal
OB400P01GN	Door with MP Logo	NBR
OB400P02GN	Blank cover	NBR
OB400P01GV	Door with MP Logo	FPM
OB400P02GV	Blank cover	FPM

Code	Description
OB400P01	Door with MP Logo
OB400P02	Blank cover
GU0400DINNBR	Seal
GU0400DINVTN	Seal

Dimensions

			OB350		
	Nr.4x ϕ 12		Holes on the tank		
	ϕ 350	ϕ 324	23	ϕ 248	
	Code	Description	Seal		
	OB350P01GN	Door with MP Logo	NBR		
	OB350P02GN	Blank cover	NBR		
	OB350P01GV	Door with MP Logo	FPM		
	OB350P02GV	Blank cover	FPM		
	Code	Description			
	OB350DIN000	Door			
	GU0350DINNBR	Seal			
	GU0350DINVTN	Seal			
			OB356		
	Nr.6x ϕ 12		Holes on the tank		
	ϕ 350	ϕ 324	23	ϕ 248	
	Code	Description	Seal		
	OB356P01GN	Door with MP Logo	NBR		
	OB356P02GN	Blank cover	NBR		
	OB356P01GV	Door with MP Logo	FPM		
	OB356P02GV	Blank cover	FPM		
	Code	Description			
	OB356DIN000	Door			
	GU0350DINNBR	Seal			
	GU0350DINVTN	Seal			
			OB475		
	Nr.6x ϕ 12		Holes on the tank		
	ϕ 475	ϕ 449	25	ϕ 383	
	Code	Description	Seal		
	OB475P01GN	Door with MP Logo	NBR		
	OB475P02GN	Blank cover	NBR		
	OB475P01GV	Door with MP Logo	FPM		
	OB475P02GV	Blank cover	FPM		
	Code	Description			
	OB475P01	Door with MP Logo			
	OB475P02	Blank cover			
	GU0475DINNBR	Seal			
	GU0475DINVTN	Seal			

LVA

LVA visual level indicators (see page 96) can also be mounted on MP Filtri cleaning covers to improve the maintenance and the service level.

Indicator code	OB275**	OB350**	OB356**	OB400**	OB475**
LVA 10**	•	•	•	•	•
LVA 20**		•	•	•	•
LVA 30**				•	•

Note:
Preparing for to fit the level on request

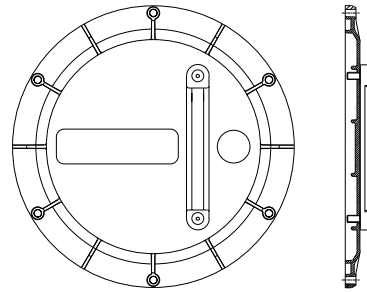

LCPG42N...S

LCP spy eyes (see page 90) can also be mounted on MP Filtri cleaning covers to improve the maintenance and the service level.

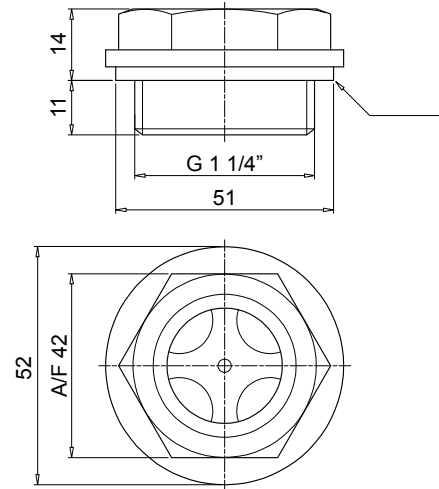
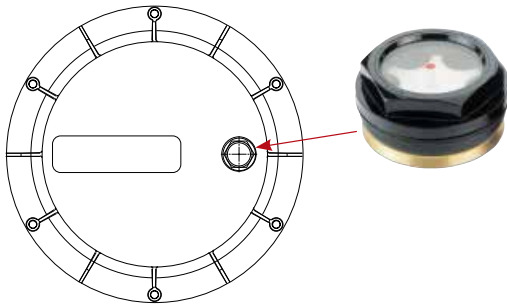

LEG

LEG series electrical level indicators (see page 106) are supplied with a 3-hole fixing flange and a reed switch having NC-NO contacts. Designed typically for installation on the vertical walls of oil tanks, these devices can also be mounted onto OB475 inspection door to indicate the minimum and maximum oil levels in the tank. To operate correctly, the float must be positioned vertically and at a minimum distance of 35 mm from walls made of ferrous metal.

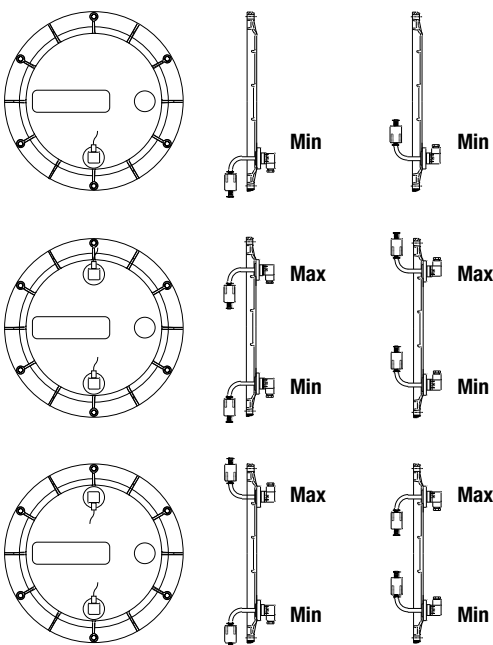

Layout of fixing holes for LEG level indicator

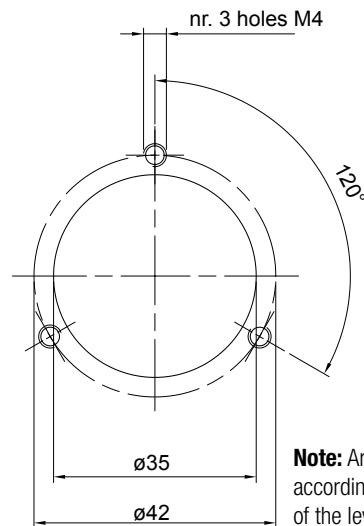

Note: Prepared for visual indicator on request

Note: Arrange the holes according to the position of the level indicator